

VTFM300-Mini electromagnetic flow meters

- ▶ Compact design saves installation space
- ▶ Corrosion resistance sensor technology
- ▶ All electronic design with no moving parts
- ▶ Automatic viscosity temperature compensation
- ▶ Pulse output/analog output is optional
- ▶ Low pressure loss
- ▶ Strong anti-fouling ability
- ▶ Air traffic control measurement function
- ▶ Temperature resistance -40~100 degrees Celsius



FLOW

According to Faraday's principle of electromagnetic induction when a conductor passes vertically through magnetic field B, it will induce a voltage. U In the measurement of the flowmeter, the moving conductor is a flowing conducting medium, and the magnetic field B is emitted from the direction perpendicular to the flowing medium. The induced electromotive force U on the two electrodes E1 and E2 is directly proportional to the velocity V of the medium.

$$U=K \times B \times V \times D$$

K-meter constant

D-Internal probe spacing

The induced electromotive force U is further processed and converted into a standard electrical signal for output or display

Specifications

Measuring Range	0.04...120L/Min
Nominal diameter	DN6...DN15
Applicable medium	Liquid with conductivity > 10us /cm
Accuracy	≤±1% range, 0.5% range (optional)
Repeatability	≤±0.2% range
Proof pressure	16 bar
Operating voltage	24±10%Vdc
Current consumption	≤80mA
Electrical Protection	Reverse polarity protection, short circuit protection
Output	
Pulse output	NPN output, pull up resistor 2K
Analog output	4... 20mA, current limit 26mA, load resistance < 250?
Response Time	<500ms
Ambient Temperature	-25...85°C
Medium Temperature	-40...100°C
Materials	
Electrode	Stainless Steel 316T1
Process Connection	Stainless Steel 316T1
Measuring tube	PEEK
Seal	EPDM
HousingHousing	Stainless Steel 304
Electrical Connection	M12×1 Plug
Process Connection	G External thread, 25.4 chuck, 50.5 chuck

Applications

- ▶ Circulating water detection
- ▶ Coolant monitoring
- ▶ Other conducting liquid monitoring

External thread connection

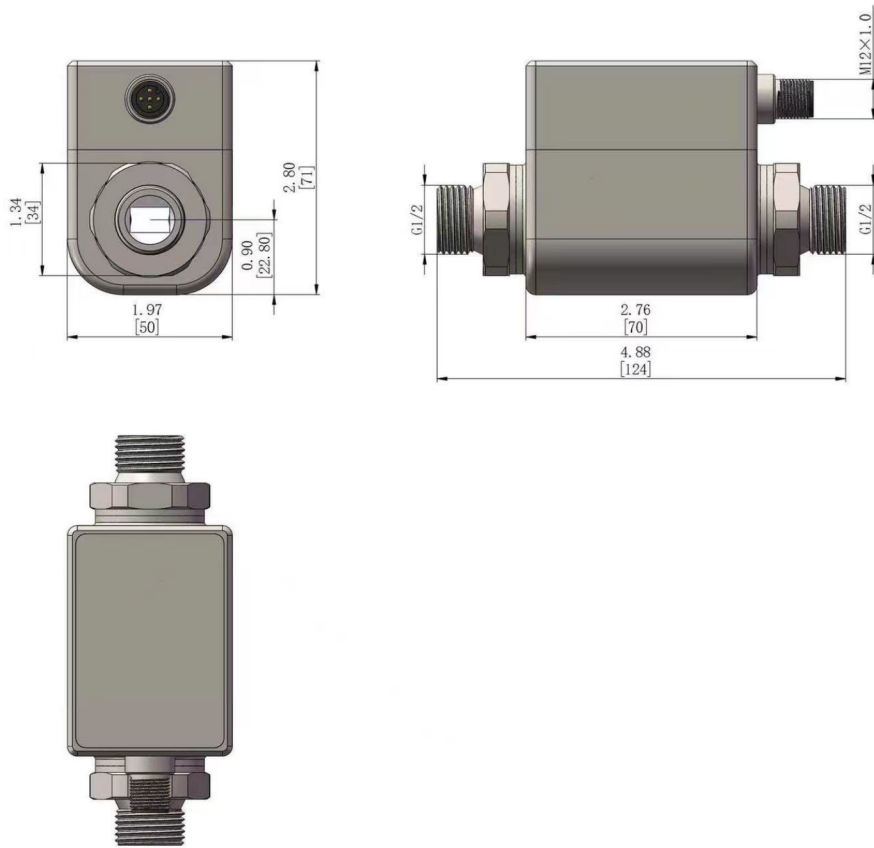

Wiring

Signal	Plug	Cable
U+	1	Brown
U-	3	Blue
Pulse output	4	Black
Analog output (voltage or current)	2	White

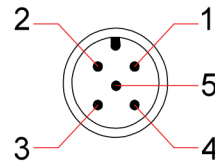

Flow Range L/min

Optional procedure connection			Measuring range l/min	DN
G1/4	1/4" NPT	25.4Sanitary chuck	0.05-15	DN6
G1/2	1/2" NPT	25.4Sanitary chuck	0.2-50	DN10
G3/4	3/4" NPT	50.5Sanitary chuck	0.5-120	DN15

Model Number

OrderNO.	Type	Process connection G External thread/chuck	Measuring range L/Min	DN
VTFM3006	VTFM300GM06	G1/4	0.04-15 L/min	6
VTFM3010	VTFM300GM10	G1/2	0.1-50L/min	10
VTFM3015	VTFM300GM15	G3/4	0.24-120L/min	15
VTFM3106	VTFM300TR106	25.4 Sanitary chuck	0.04-15 L/min	6
VTFM3110	VTFM300TR110	25.4 Sanitary chuck	0.1-50L/min	10
VTFM3115	VTFM300TR215	50.5 Sanitary chuck	0.24-120L/min	15