



VTTA-305

Temperature Transducer

Product Description

VTTA-305 series is a compact and durable temperature transmitter, which uses thermal resistance for temperature measurement, and the signal is converted into a standard industrial electrical signal output by the post-processing circuit. The all-metal casing design enables this series of products to be used in various industrial occasions. The analog output type is: 4...20mA, a variety of connection methods can fully meet various specific installation needs.

Features

- The ultra-small and integrated high temperature module is easy to install and convenient for system networking and wiring.
- Measuring range from -50°C...200°C
- Compact structure
- Stainless steel shell

Application

- Hydraulic and pneumatic Circulating water/coolant Mechanical manufacturing
- Oil and gas industry
- Water treatment
- Building automation

Parameters

Supply voltage	10...30Vdc
2 wire type	Consistent with the output signal current (4... 20 mA)
Output type	2-wire 4... 20 mA
load RA(Ω)	$RA \leq (U_s - 10)V / 0.02A$
Non-linearity	± 0.5% F.S
Sensor	PT1000 Class A
Accuracy	± 0.5% range
Stability (annual drift amount)	± 0.25% range
Medium temperature (measurement range)	-50...100°C / -50...150°C / -50...200°C
Ambient temperature	-20...+85°C
Withstand pressure	200bar
Shell material	Stainless Steel 304
Contact medium material	Stainless Steel 316
levels of protection	IP67 (M12connector)
Output type	M12 connector
Procedure linkage	G1 / 4 outer thread

接线方式

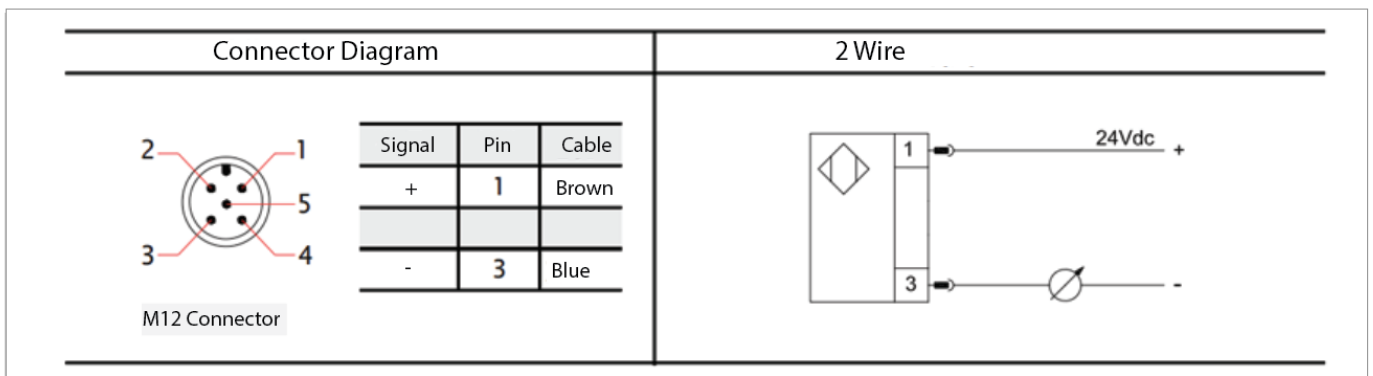

尺寸 in inch[mm]

With cooling neck



Standard

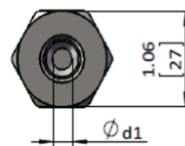
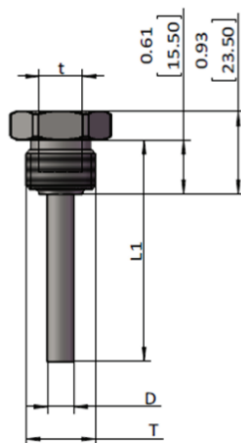
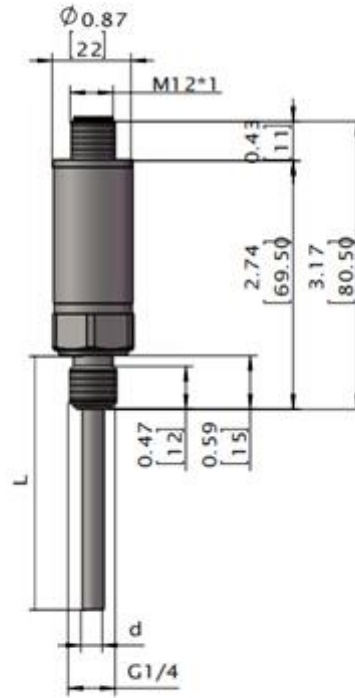

Probe with neck tube cooling structure -- for 0°C-200°C

Upper Limit	L2	
	inch	m m
125 °C	0	0
400 °C	1.97	50
600 °C	3.94	100

T	t	d	d1	D	L1
G1/2	G1/4	6	8	10	L-15