



VTM530-A

Pressure Transmitters

FEATURES

- Heavy Industrial CE Tested
- Integral Pressure Cavity, No leakage
- Reverse Polarity Protection on Input
- Short Circuit Protection on Output
- Up to $\pm 0.25\%$ Accuracy
- Up to $\pm 1\%$ Total Error Band
- Compact Outline
- -40°C to $+120^{\circ}\text{C}$ Operating Temperature
- Weatherproof

SPECIFICATIONS

- High Accuracy
- Compact
- Variety of Pressure Ports and Electrical Configurations
- Optional damper
- CE Compliant and Weatherproof
- Gage, Compound
- High Accuracy

APPLICATIONS

- Industrial Process Control and Monitoring
- Advanced HVAC Systems
- Refrigeration Systems
- Automotive Test Stands
- Off-Road Vehicles
- Pumps and Compressors
- Hydraulic/Pneumatic Systems
- Agriculture Equipment
- Energy Generation and Management

STADARD RANGES

Measuring Method	Range (psi)	Range (Bar)	Gage	Sealed	Absolute	Compound	
Piezoresistive pressure sensor (Relative pressure)		-1 to +1					
		0 to 2					
		0 to 6					
Metal Thin-film pressure sensor or Micro-fused pressure sensor (Relative pressure)		0 to 10					
		-1 to +10					
		0 to 16					
		0 to 25					
		0 to 50					
	0 to 100	0 to 7	•				
	0 to 150	0 to 10	•				
	0 to 250	0 to 16	•			•	
	0 to 500	0 to 35	•			•	
	0 to 1000	0 to 70	•			•	
	0 to 1500	0 to 100	•			•	
	0 to 2250	0 to 150	•			•	
	0 to 3000	0 to 200	•			•	
	0 to 5000	0 to 350	•			•	
	0 to 7500	0 to 500	•			•	
	0 to 10000	0 to 700	•			•	
	0 to 15000	0 to 1000	•			•	● S
0 to 22000	0 to 1500	•			•	● S	
0 to 35000	0 to 2500	•			•	● S	
Consult manufacture to custom order, ●S							

Intermediate ranges available upon request. Ambient Temperature: 25°C (unless otherwise specified)

PERFORMANCE SPECIFICATIONS

PARAMETERS	MIN	TYP	MAX	UNITS	NOTES
Accuracy (RSS of Non-linearity, hysteresis, and repeatability)		±0.5		%F.S. BFSL	@ 25°C
Accuracy ±FS1)	1			%F.S. BFSL	
Isolation, Body to any Lead	100			MΩ	@250VDC
Dielectric Strength			2	mA	@500VAC, 1min
Pressure Cycles	1X10 ⁷			0~FS Cycles	
Proof Pressure	2X		20k psi Rated		
Temperature of medium [°C]	0 ... 80				
Ambient temperature [°C]	0 ... 80				
Burst Pressure	5X		20k psi Rated		

Long Term Stability (1 year)	-0.25		0.25	%F.S	
Total Error Band	-2	±1.0	2	%F.S	Over compensated temperature range
Compensated Temperature	0		70	°C	
Operating Temperature	-40		120	°C	
Storage Temperature	-55		+130	°C	
Load Resistance (R_L)	RL > 100k			Ω	Voltage Output
Load Resistance (R_L)	< (Supply Voltage -9V) / 0.02A			Ω	Current Output
Current Consumption			10	mA	Voltage Output
Rise Time (10% to 90%)	<2ms (Voltage Output); <3ms (Current Output); Without Snubber				
Pressure Port Material	17-4PH or SST316L				
Shock	50g, 11msec Half Sine Shock per MIL-STD-202G, Method 213B, Condition A				
Vibration	±20g, MIL-STD-810C, Procedure 514.2-2, Curve L				
Operating Voltage (VDC)	8.....30				
Electrical Connection	Plug M12x1, 4-pin, to EN 60947-5-2, round design				
Pressure Inlet	Relative pressure				
Pneumatic connection	G1/4 or chosen from order code				
Electrical output 1	4 ... 20 mA, 0 ... 10 V, 0 ... 5 V				
Linearity error ±FS1 %	0.5				

MACHANICS

Type of mounting	With female thread Via accessories		
Mounting position	Any		
Pneumatic connection	G1/4 or chosen from order code		
Product weight [g]	120		
Information on materials: housing	High-alloy stainless steel	PA	VMQ (silicone)
Materials in contact with the medium)	High-alloy stainless steel		
Degree of protection	IP67		
Corrosion resistance class (CRC2)	4		

DIMENSIONS [mm]

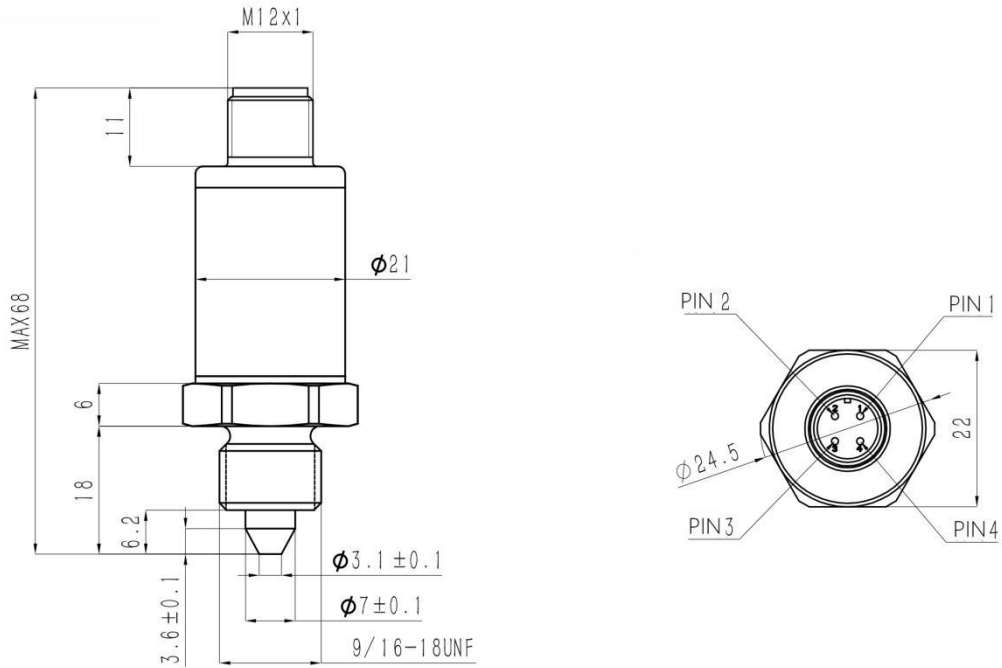

CODE	PRESSURE PORT TYPE		
	PORT	DIM "A"	DIM "B"
1	G1/4 JIS B2351	0.472 [12.00]	0.3 [8.0]
2	M20 x 1.5 mm ISO 6149-2	0.661 [16.8]	0.3 [8.0]
3	1/4-18 NPT	0.600 [15.24]	0.3 [8.0]
4	7/16-20UNF FEMALE SAE J513 STRAIGHT THREAD WITH INTEGRAL VALVE DEPRESSOR	0.687[17.5]	0.3 [8.0]
5	M14 x 1.5 mm ISO 6149-2	0.472[12.0]	0.3 [8.0]
6	1/8-27 NPT	0.390[9.91]	0.3 [8.0]
7	M12 x 1.5 mm ISO 6149-2	0.472[12.0]	0.3 [8.0]
8	M10 x 1.0 mm ISO 6149-2	0.374[9.5]	0.3 [8.0]
9	G1/4 DIN 3852 FORM E GASKET DIN3869-14 NBR	0.512 [13.00]	0.3 [8.0]

WIRING DIAGRAMS

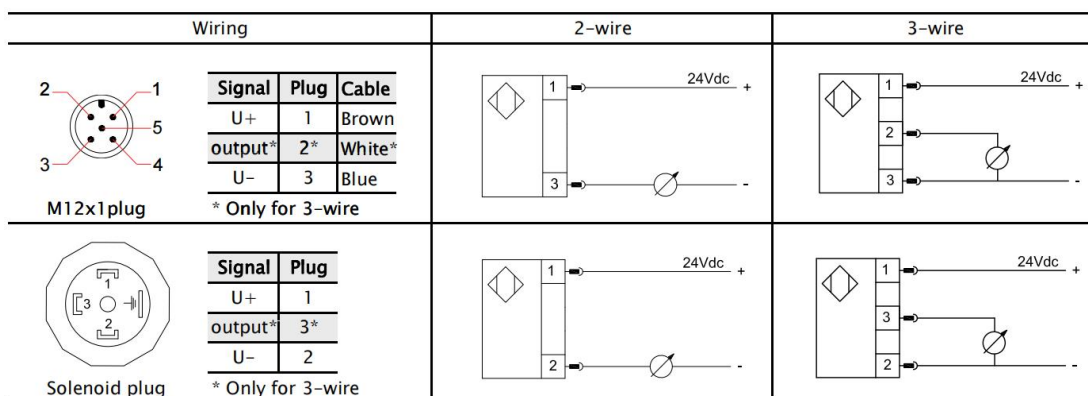

CODE	CONNECTION TYPE	DIM C (MAX)
1	CABLE 3 FT	1.97 [50.0]
2	CABLE 10 FT	1.97 [50.0]
3	PACKARD CONNECTOR	2.10 [53.5]
4	NEBU-M12 CONNECTOR	1.71 [43,5]
5	FORM A CONNECTOR	1.93 [49.0]

For custom configurations, consult factory.

Notes

Compensated Temperature: The temperature range over which the product will produce an output proportional to pressure within the specified performance limits.

Operating Temperature: The temperature range over which the product will produce an output proportional to pressure but may not remain within the specified performance limits.

Storage Temperature: The temperature range over which the product can be stored safely in occasions without pressure applied or power input and remains rated performance. Beyond this temperature range may cause permanent damage to the product.

All configurations are built with supply voltage reverse and output short-circuit protections.

CE Compliance (For reference only)

EN 55022 Emissions Class A & B

IEC 61000-4-2 Electrostatic Discharge Immunity (8kV contact/15kV air)

IEC 61000-4-3 Radiated, Radio-Frequency Electromagnetic Field Immunity (10V/m, 80M-1GHz)

IEC 61000-4-4 Electrical Fast Transient Immunity (1kV)

IEC 61000-4-5 Surge Immunity (V+ to V-: ±2KV/42Ω; L to Case: ±1KV/12Ω; V- to V0: ±1KV/42Ω)

IEC 61000-4-6 Immunity to Conducted Disturbances Induced by Radio Frequency

Fields (150K~80MHz, 10V level for voltage output models, 3V level for current output model)

IEC 61000-4-9 Pulse Magnetic Field Immunity (100A/m peak)

For all CE coFpliance tests, max allowed output deviation ±1.5 %F.S

WATERPROOF

WEATHER-PROOF RATING	
CONNECTION	P CODE
PACKARD CONNECTOR	IP66
CABLE	IP67
M12 CONNECTOR	IP67
FORM A CONNECTOR	IP65

OUTPUTS

CODE	OUTPUT SIGNAL	SUPPLY VOLTAGE
1	0.5 - 4.5V	5 ± 0.25V
	RATIOMETRIC	PROTECTED to 16V
2	1 - 5V	8 - 36V
3	4 - 20mA	9 - 36V
4	0 - 5V	8 - 36V
5	0 - 10V	13 - 36V
6	1 - 6V	8 - 36V
7	0.5 - 4.5V	7.5- 36V
8	I2C	3.3V or 5V

WIRING

Current Output Wiring					
CONNECTION	+SUPPLY	-SUPPLY	NC. PINS		P REF VENT
Packard, A	A	B	C		Hole Through Connector
Packard, B	B	A	C		
FORM A	1	2	3,4		
M12	1	2	3,4		
CABLE	RED	BLK			Pipe In Cable
Voltage Output Wiring					
CONNECTION	+SUPPLY	+OUTPOT	COMMON	NC. PINS	P REF VENT
Packard, A	A	C	B	4	Hole Through Connector
Packard, B	B	C	A		
FORM A	1	3	2		
M12	1	3	2		
CABLE	RED	WHT	BLK		Pipe In Cable

CONNECTION TYPES

CONNECTION	DESCRIPTION	MATING HOUSING P/N	MATING TERMINAL PIN
Packard	3-PIN METRI-PACK 150	12078090	12103881, QTY 3
M12	BINDER SERIES 713, 09 3431 77 04 OR EQUIV	4-POS FEMALE CONNECTOR	

Note: Transmitter of gage pressure type requires vent to atmosphere on the pressure reference side. This is accomplished via cable from the transmitter (the end of the cable should be terminated to clean and dry area) or through the customer mating connector/cable assembly which has internal vent path.

Suggested vented M12 mating connector P/N MB12FWAFF04ST-4 and MB12FWAFF04ST-3 at www.finecables.com for 0.157"~0.236" and 0.236"~0.315" diameter cable respectively.

FORM A	OMAL ARB03S or ARB03R	OMAL AHB6733 3+PE	
--------	-----------------------	-------------------	--

ORDERING INFORMATION

VTM530-A	3	4	1	0	0	9	2500B	G
Model	Output Signal	Connection Type	Port Material	Snubber	Label	Pressure Port	Pressure Range	Pressure Type
VTM530-A	1: 0.5 - 4.5V RATIOMETRIC	1: CABLE	1: 304 Screw+ 17-4 Diaphragm	0: No Snubber	0: No Label (OEM)	1: G1/4 JIS B2351	B: Bar M: Mpa P: PSI K: Kpa	G: Gage
	2: 1 - 5V	2: PACKARD A	2: 17-4 Integral Screw	1: With Snubber	1: Adhesive Label	2: M20 x 1.5 3: 1/4-18 NPT		C: Compound
	3: 4 - 20mA	3: PACKARD B	3: *SST316L Port+304 Hex		2: Laser Marking	4: 7/16-20UNF FEMALE SAE		
	4: 0 - 5V	4: M12	X: Customer			5: M14 x 1.5		
	5: 0 - 10V	5: FORM A	SPecial			6: 1/8-27 NPT		
	6: 1 - 6V					7: M12 x 1.5		
	7: 0.5 - 4.5V					8: M10 x 1.0		
	8: I ² C					9: G1/4 DIN 3852		
X: Customer					CUS. 9/16-18UNF -2A external thread			

Order code : VTM530A 3 4 1 0 2 C 2500B G