

**VTFC 08-Thermal Flow Sensor**

- ▶ Wide measuring range
- ▶ Setting point or measuring range programmable through keys
- ▶ More parameters programmable through hand-held device or computer
- ▶ 8 LEDs display for switching status and flow trend
- ▶ Compact design (diameter 36mm)
- ▶ PNP/NPN/Relay output selectable
- ▶ Protection level IP67

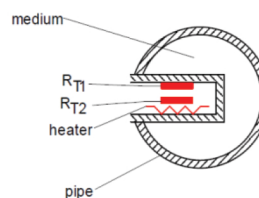

Based on thermodynamic principle, VTFC08 features 2 temperature sensors inside the probe: one for medium temperature, the other one is heated a few degrees up compared to the medium into which it projects. When the medium flows, the heat generated in the sensor is conducted away by the medium. The difference between these two sensors can be measured to get the flow rate. All-metal housing; 8 LEDs for switching status and flow trend display; No moving parts to minimize maintenance; Applicable to various medium.



**Specifications**

<b>Measuring Range</b>	
Water	1...200cm/s
Oil	3...300cm/s
Air	20...2000cm/s
<b>Applicable Medium</b>	Water, oil and gas which is compatible with stainless steel
<b>Repeatability</b>	1%@<0.6m/s; 3%@<1.5m/s; 10%@>1.5m/s
<b>Pressure Rating</b>	100bar
<b>Initialization Time</b>	1...8s
<b>Response Time</b>	2s typical
<b>Power Supply</b>	18...30Vdc
<b>Current Consumption</b>	≤40mA(power supply 24Vdc, no-load)
<b>Switching Output(NC+NO)</b>	
Output type	PNP/NPN/relay output optional, NC/NO programmable
Load capacity	500mA (power supply 24Vdc, NPN/PNP output),
<b>Wiring Protection</b>	Reverse polarity, overvoltage and short-circuit
<b>Display</b>	
	3 red LEDs (flow velocity < switch point)
	1 yellow LED (flow velocity = switch point )
	4 green LEDs (flow velocity > switch point)
<b>Temperature</b>	
Operating/storing	-40...85°C
Medium	-20...85°C
<b>Material</b>	
Housing	304stainless steel
Probe	304stainless steel
<b>Protection Class</b>	IP67
<b>Electrical Conection</b>	M12×1 plug

**Applications**

- ▶ Hydraulic /Lubrication
- ▶ Pump protection
- ▶ Cooling System
- ▶ Ventilation system
- ▶ Water treatment
- ▶ Leaking test

**LED Function & Setup**

■ ■ ■ □ □ □ □ □	Red LED indicates that current flow is less than switch point.
■ ■ ■ ■ □ □ □ □	Yellow LED indicates that switch point was reached and switch state changes.
■ ■ ■ ■ ■ □ □ □	Green LED indicates that current flow is higher than switch point, switch keeps state. More green LEDs indicate higher flow rate.

Install the switch properly and set the flow rate to what you want to monitor, adjust the switch using the magnetic bar to make the first green light on. Once done, switch state changes if flow rate is lower than current flow.

Setup through Magnetic bar, hand-hold device or computer



Dimensions in inch[mm]

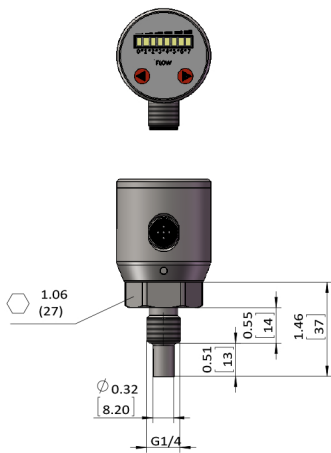

G1/4 Probe

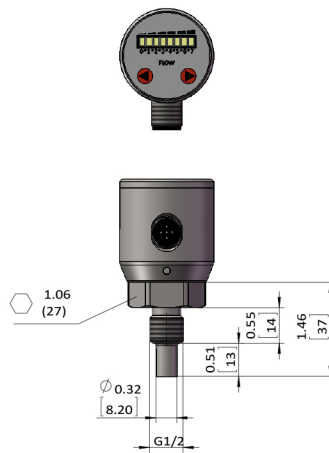

G1/2 Probe

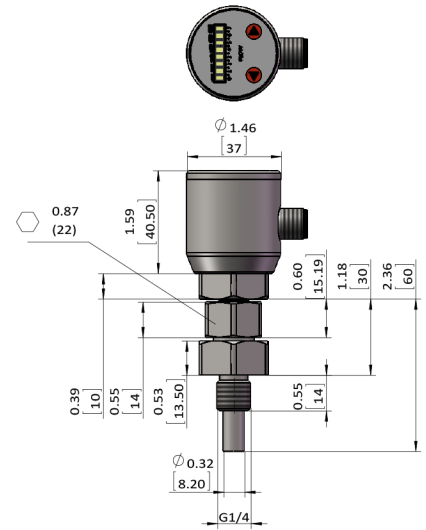

F18 Probe

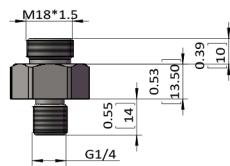

FG14 Accessory

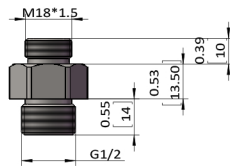

FG12 Accessory

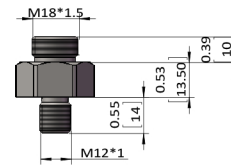

FM12 Accessory

**Wiring**

Signal	Plug	Cable
U+	1	Brown
U-	3	Blue
Output 1	4	Black
Output 2	2	White
Communication	5	Gray

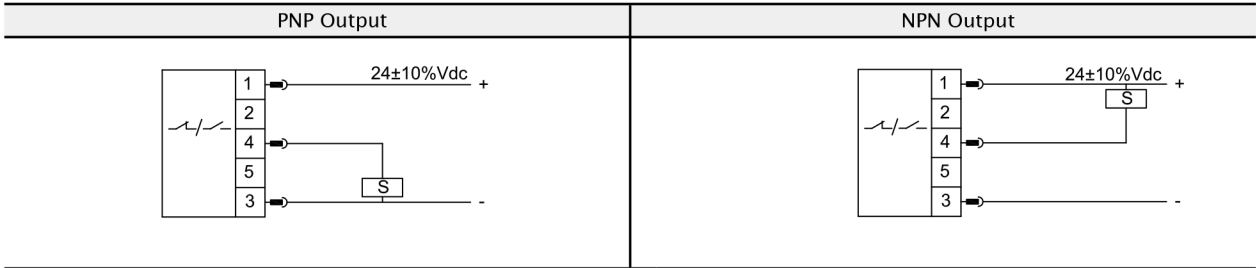
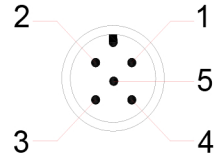

**Model Number**

OrderNO.	Type	Rod length mm	Process connection
VTFC8000	VTFCR08/RG14MSM027	27	G1/4
VTFC8001	VTFCR08/RG12MSM027	27	G1/2
VTFC8002	VTFCR08/RF18SM060	60	M18 union