

VTFN3000 - Thermal Flow Switch with LED Digital Display

- ▶ 4-digit LEDs
- ▶ Flow velocity/percentage display
- ▶ Wide measuring range
- ▶ Measuring span programmable
- ▶ PNP / NPN programmable
- ▶ 4...20mA/0...20mA/1...5V/0...5V output programmable
- ▶ Rotatable indicator, easy to read, robust display



FLOW

Based on thermodynamic principle, VTFN3000 features 2 temperature sensors inside the probe: one for medium temperature, the other one is heated a few degrees up compared to the medium into which it projects. When the medium flows, the heat generated in the sensor is conducted away by the medium. The difference between these two sensors can be measured to get the flow rate. Compared to traditional products, VTFN3000 offers wider measuring range, less temperature drifting, as well as percentage or flow velocity display. All metal housing, highlighted digital LED, dual-key and user-friendly interface, multiple process connections. 330° rotatable indicator.

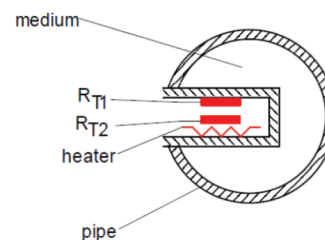

Specifications

Measuring Range	
Water	1...200cm/s
Oil	3...300cm/s
Air	20...2000cm/s
Applicable Medium	Water, oil and gas which is compatible with stainless steel
Repeatability	1% @ <0.6m/s; 3% @ <1.5m/s; 10% @ >1.5m/s
Pressure Rating	100bar
Initialization Time	1...8s
Response Time	2s typical
Power Supply	18...30Vdc
Current Consumption	≤500mA (power supply 24Vdc, no-load)
Switching Output (NC+NO)	
Output	Push-pull (compatible with PNP / NPN); NC / NO configurable
S1, S2 Output Current	<500mA
Voltage Drop	<1V
Current Analog Output	
Output	3-wire 0...20mA / 4...20mA programmable
Load RA	RA ≤ 0.5KΩ
Wiring Protection	Reverse polarity, overvoltage and short-circuit
Display	
Design	8mm height, red 4-digit LED
Display Range	-1999...9999
Temperature	
Operating	-40...85°C
Medium	-20...85°C
Material	
Housing	304 stainless steel
Probe	304 stainless steel
Protection Class	IP67
Electrical Connection	M12×1 plug

Applications

- ▶ Hydraulic / Lubrication
- ▶ Pump protection
- ▶ Cooling water monitoring
- ▶ Ventilation system
- ▶ Leaking test
- ▶ Machinery manufacture
- ▶ Water treatment
- ▶ Engineering project

Set Panel

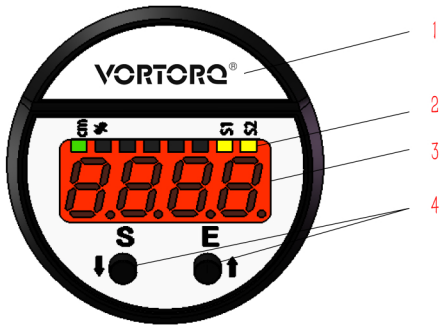

- 1- LOGO
- 2- 8 state lights
- 3- 4-digit LED display window
- 4- Keys

S + E	Press and hold for 2 seconds to enter setting mode/verification
S	Shift down the menu / change values
E	Shift up the menu / Change values

Functional Specifications

Hysteresis Mode

The hysteresis keeps the switching output stable if the flow velocity fluctuates around the setpoint. Output switches when rising flow velocity reaches set point (SP1); As flow velocity falls, the output switches back only if the reset point(rP1) is reached.

Hysteresis Mode

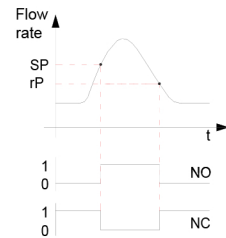

Window Mode

The window function allows the monitoring of a defined range. If the flow velocity is between set point (SP1) and reset point (rP1), the output is activated (NO), otherwise it is deactivated(NC).

Window Mode

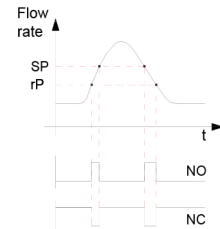

Dimensions in inch[mm]

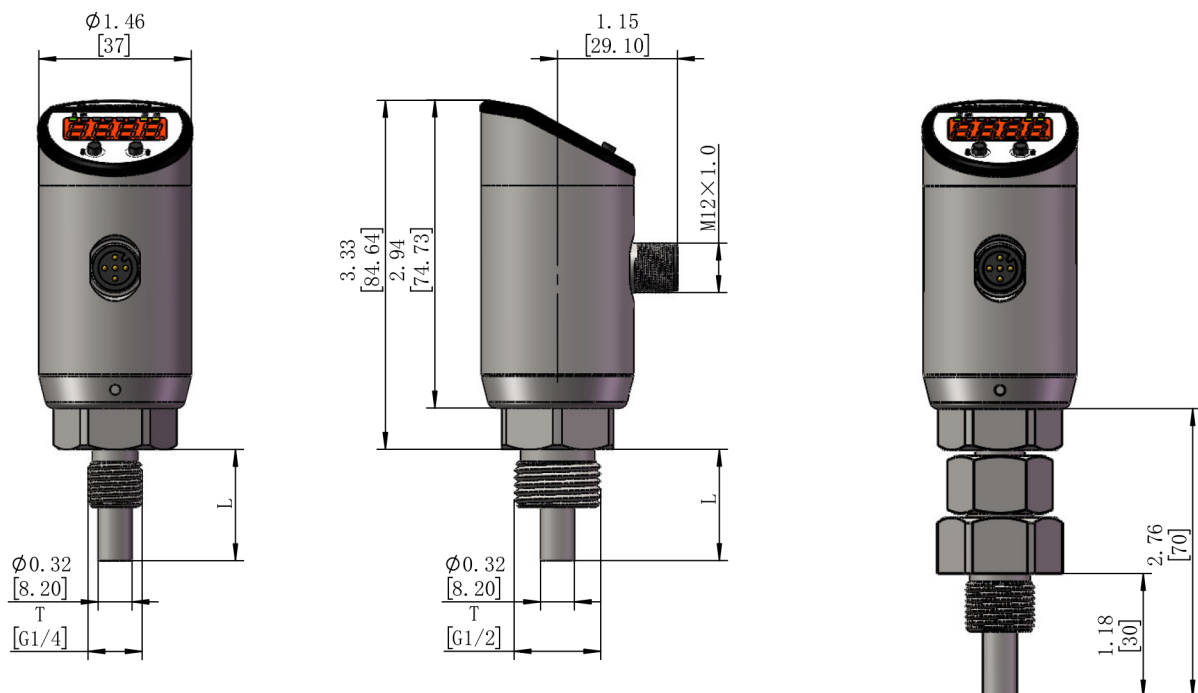

Dimensions in inch[mm]

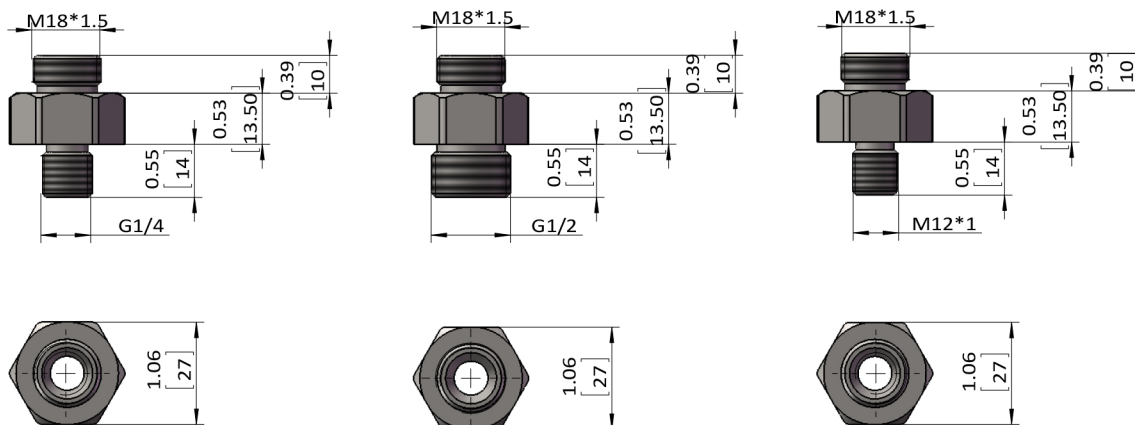

Note: One of the connectors FG12, FM12 or FG14 must be ordered for sealing purpose if probe is F18

Wiring

Signal	Plug	Cable
U+	1	Brown
U-	3	Blue
Switching output S1	4	Black
Switching output S2	2	White
Analog output (Current or Voltage)	5	Gray

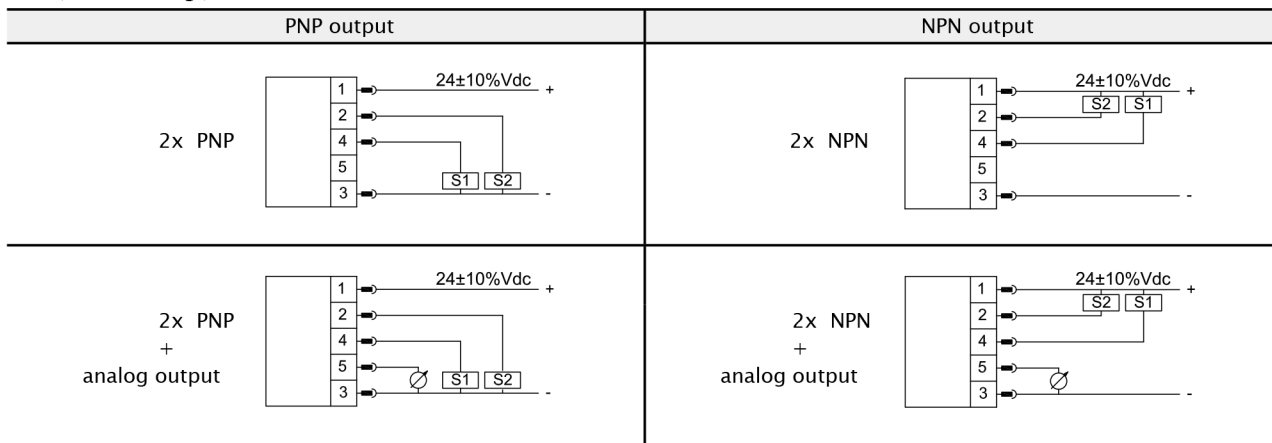

Model Number

OrderNO.	Type	Rod length mm	Process connection
VTFN3000	VTFN3000/G14M21M027S	27	G1/4
VTFN3001	VTFN3000/G12M21M027S	27	G1/2
VTFN3002	VTFN3000/G1821M060S	60	M18 union